

DIGITUS® Workstation (monitor, keyboard, mouse) Wall Mount

DA-90451

EAN 4016032486398



Workstation (Monitor, Keyboard, Mouse) Wall Mount 32 inch, 8 kg, VESA 75x75/100x100, white/black

The DIGITUS® Workstation gives you the option of flexible configuration for a workspace via wall installation. The monitor mount supports monitors up to 32" (VESA 75x75 / 100x100) with a max. weight of 8 kg. The shelf for keyboard and mouse also offers a max. load capacity of 8 kg. Both arms can be individually height adjusted based on the carrier mount that is installed on the wall.

Universal mount for installation monitor and keyboard/mouse on the wall with flexible height adjustment

- Monitor arm (gas spring) - 45° inclination, 180° swivel range, VESA mounts 360° rotation range
- Monitor arm suited for monitors up to 32" and max. weight of 8 kg (VESA 75x75, 100x100)
- Mount for keyboard & mouse (double hinged arm) - Size: W 60 x D 17.8 cm and handle on the front side

- Double hinged arm with a load capacity of max. 8 kg - Swivel range up to 180°
- Individual height adjustment of both arms on the carrier mount (height 73 cm)
- Integrated cable management
- Easy wall installation using three screws
- High-quality aluminum/steel design
- Dimensions:
- Height 73 cm
- Depth: 25-67 cm
- Weight: 4.05 kg
- Color: White/Black

Package contents

- 1x Workspace - wall installation
- 1x Mounting material
- 1x QIG

Logistics						
	Number (pcs)	Weight (kg)	Depth (cm)	Width (cm)	Height (cm)	cm ³
Packaging Unit Carton	2	10.28	26.00	78.50	25.00	51.03
Packaging Unit Inside	1	5.14	23.50	77.00	11.00	19,904.50
Packaging Unit Single	1	5.14	23.50	77.00	11.00	19,904.50
Net single without Packaging	0	4.05	67.00	60.00	73.00	293.46

More images:

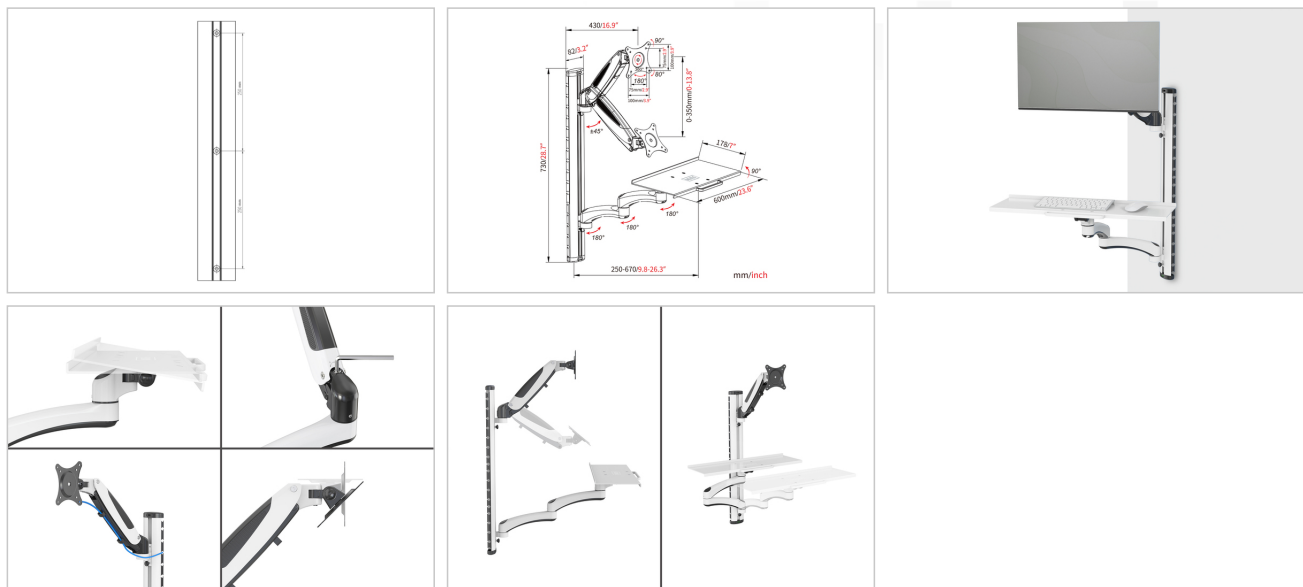

Safety notes

- Please read the entire manual before starting assembly and installation. Please contact your local dealer if you have any questions about the instructions or warnings.
- CAUTION: Use with products that exceed the permitted weight may result in damage or possible injury.
- Brackets should be fitted in accordance with the installation instructions. Incorrect installation can result in damage or injury.
- Use safety equipment and suitable tools. The product should only be installed by specialists.
- The load-bearing surfaces should be able to safely withstand the entire weight of appliances and all additional components.
- Only use the installation screws supplied and DO NOT TIGHTEN the screws TOO TIGHT.
- This product contains small parts that can cause a choking hazard if swallowed. Keep these parts away from children.
- Only use this product indoors. Using the product outdoors can lead to injuries and damage.
- IMPORTANT: Before installation, please check all components received against the components list. If parts are damaged or missing, ask your local dealer for replacement parts.

EU responsible person

EU based economic operator ensuring the product complies with the required regulations.

ASSMANN Electronic GmbH
 Auf dem Schüffel 3
 Lüdenscheid, Germany
<https://www.assmann.com>
info@assmann.com