

# DIGITUS Suporte triplo de monitor com fixação de aperto

DA-90362  
EAN 4016032425007

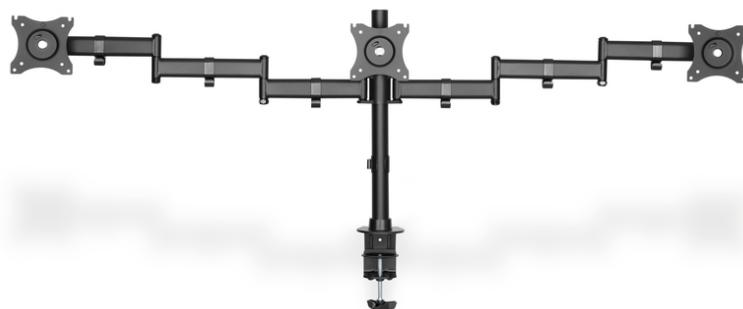

### Triple Monitor Desk Clamp Mount, 15-27",black max. load 3x8Kg,VESA max. 100x100

Suporte de monitor universal para um posicionamento flexível dos seus monitores no local de trabalho com possibilidade de inclinação e orientação simples horizontal e vertical. Ajuste simplesmente a altura de visão às suas necessidades. O suporte para monitores permite a montagem de monitores LED, LCD de todas as marcas. Tenha apenas atenção à dimensão VESA, bem como ao peso dos seus monitores, de modo a escolher um suporte adequado.

### Suporte triplo de monitor universal com fixação de aperto até 69 cm (27")

- Adequado para distâncias de acordo com a norma VESA 75 x 75 e 100 x 100 mm
- Para tampos de mesa até 7,5 m
- Para monitores até 69 cm (27")
- Carga máx. de 8 Kg por braço

- Ajuste de altura individual de 15mm para um alinhamento perfeito dos seus monitores
- Ângulo de inclinação de ajuste livre vertical até 45 graus
- Rotação até 360°
- Peso: 6,4 kg
- Dimensões: 1448 x 550 x 120 mm

#### Attributes

- Monitor weight (max.): 8 kg
- Mounting method: Clamp-mount
- Number of monitors: 3
- Size of monitors: up to 27"
- VESA mount: 75x75 mm, 100x100 mm

#### Package contents

- Suporte de monitor
- Parafusos para a montagem do monitor
- Manual de instruções

Logistics						
	Number (pcs)	Weight (kg)	Depth (cm)	Width (cm)	Height (cm)	cm <sup>3</sup>
Packaging Unit Carton	2	15.80	63.00	31.00	28.50	55,660.50
Packaging Unit Inside	1	7.90	62.00	30.00	13.50	25,110.00
Packaging Unit Single	1	7.90	62.00	30.00	13.50	25,110.00
Net single without Packaging	1	6.40	144.80	12.00	55.00	0.00

### More images:

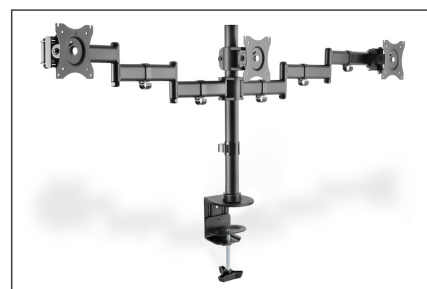
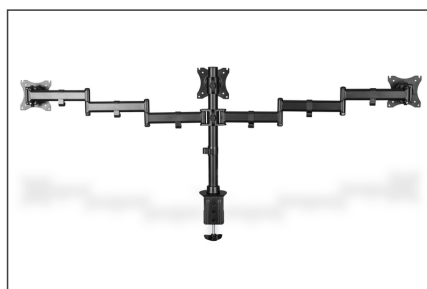
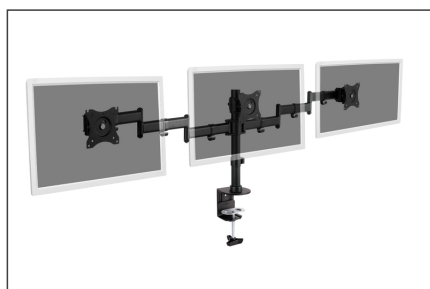

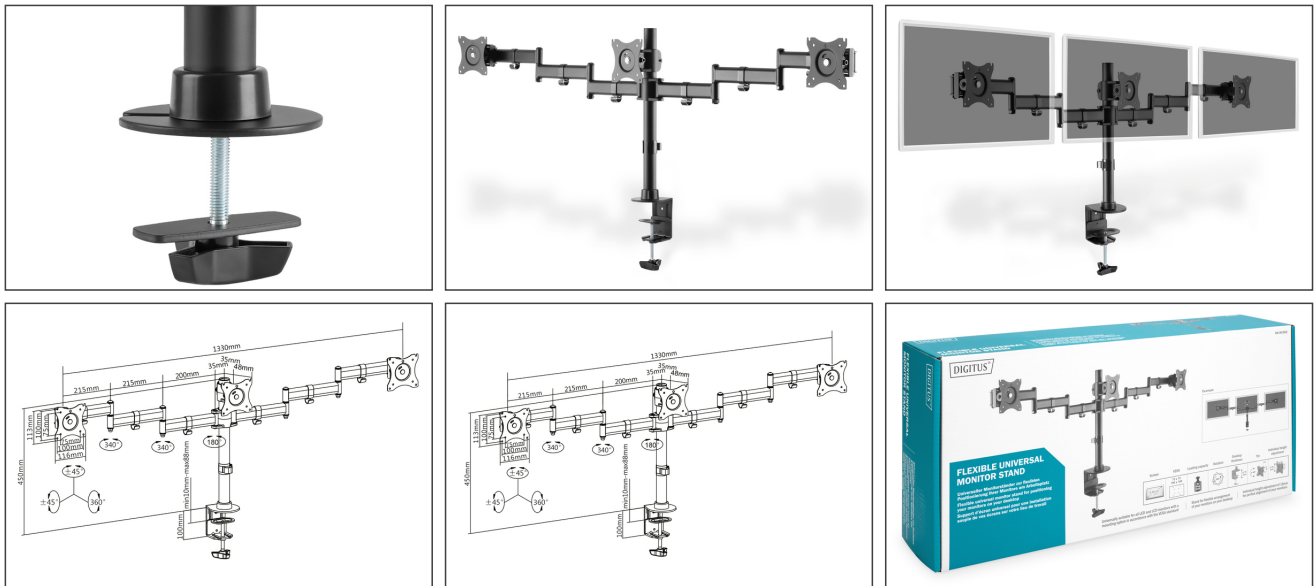

**Safety notes**

- Please read the entire manual before starting assembly and installation. Please contact your local dealer if you have any questions about the instructions or warnings.
- CAUTION: Use with products that exceed the permitted weight may result in damage or possible injury.
- Brackets should be fitted in accordance with the installation instructions. Incorrect installation can result in damage or injury.
- Use safety equipment and suitable tools. The product should only be installed by specialists.
- This product can be installed on timber-framed, solid concrete or stone walls.
- The load-bearing surfaces should be able to safely withstand the entire weight of appliances and all additional components.
- Only use the installation screws supplied and DO NOT TIGHTEN the screws TOO TIGHT.
- This product contains small parts that can cause a choking hazard if swallowed. Keep these parts away from children.
- Only use this product indoors. Using the product outdoors can lead to injuries and damage.
- IMPORTANT: Before installation, please compare all components received with the components list. If parts are damaged or missing, ask your local dealer for replacement parts.
- MAINTENANCE: Check the bracket regularly for safety and stability (preferably every three months).

**EU responsible person**

EU based economic operator ensuring the product complies with the required regulations.

ASSMANN Electronic GmbH  
 Auf dem Schüffel 3  
 Lüdenscheid, Germany  
<https://www.assmann.com>  
[info@assmann.com](mailto:info@assmann.com)