

DIGITUS® Estação de trabalho (monitor, teclado, rato) Fixação na parede

DA-90354

EAN 4016032383161

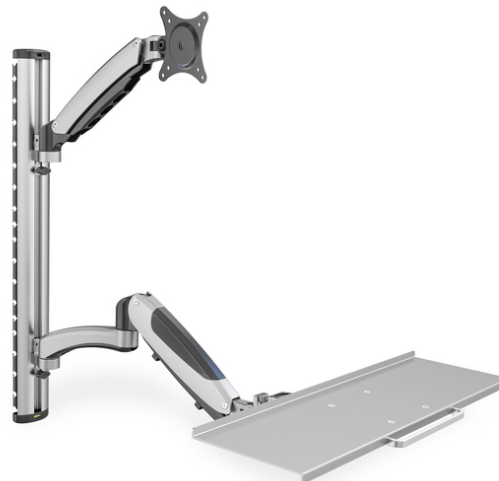

Estação de trabalho (monitor, teclado) Fixação na parede 27 polegadas, 6 kg, VESA 75x75, 100x100, prateado

Suporte de parede universal para montagem de monitores e teclados com opções flexíveis de ajuste da altura de trabalho. Em dois passos rápidos, pode montar um posto de trabalho cuja altura pode ser ajustada individualmente por várias pessoas, apesar das suas diferentes alturas. Ao selecionar o suporte, tenha apenas em atenção as dimensões VESA e o peso do seu monitor para verificar a compatibilidade.

Suporte universal para montagem de monitor e teclado na parede com ajuste flexível da altura

- Passagem de cabos integrada

- Adequado para distâncias padrão VESA de 75 x 75 e 100 x 100 mm
- Capacidade máxima de carga até 6 kg por braço
- Peso: 4,2 kg
- Dimensões: 700 x 700 x 520 mm

Attributes

- Style: PC Workstation

Package contents

- Suporte de parede
- Parafusos para montagem do monitor
- Instruções de utilização

Logistics

	Number (pcs)	Weight (kg)	Depth (cm)	Width (cm)	Height (cm)	cm ³
Packaging Unit Carton	2	12.66	78.00	25.50	23.00	45,747.00
Packaging Unit Inside	1	6.33	76.50	23.00	10.00	17,595.00
Packaging Unit Single	1	6.33	76.50	23.00	10.00	17,595.00
Net single without Packaging	1	4.82	83.40	73.00	60.00	0.00

More images:

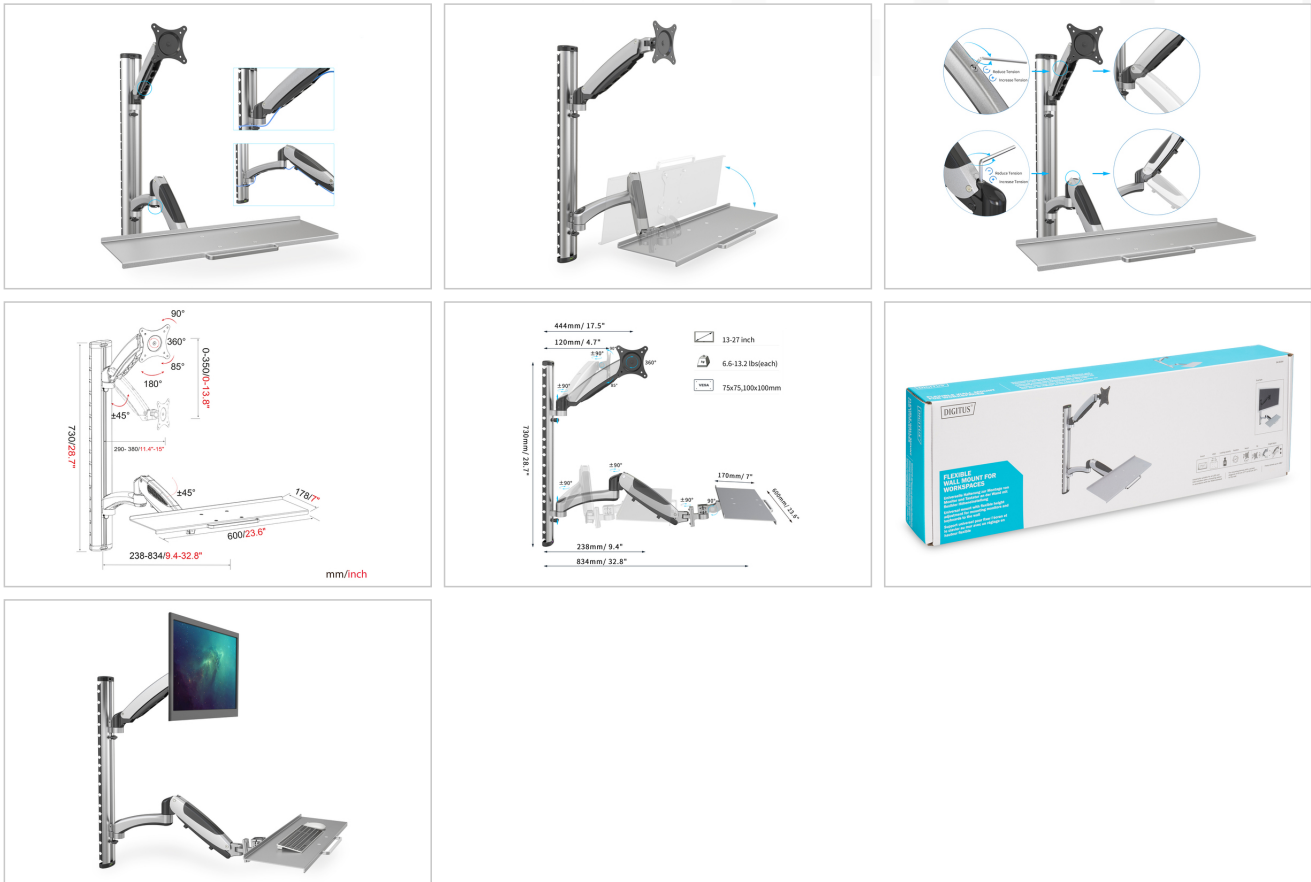

Safety notes

- Please read the entire manual before starting assembly and installation. Please contact your local dealer if you have any questions about the instructions or warnings.
- CAUTION: Use with products that exceed the permitted weight may result in damage or possible injury.
- Brackets should be fitted in accordance with the installation instructions. Incorrect installation can result in damage or injury.
- Use safety equipment and suitable tools. The product should only be installed by specialists.
- The load-bearing surfaces should be able to safely withstand the entire weight of appliances and all additional components.
- Only use the installation screws supplied and DO NOT TIGHTEN the screws TOO TIGHT.
- This product contains small parts that can cause a choking hazard if swallowed. Keep these parts away from children.
- Only use this product indoors. Using the product outdoors can lead to injuries and damage.
- IMPORTANT: Before installation, please check all components received against the components list. If parts are damaged or missing, ask your local dealer for replacement parts.

EU responsible person

EU based economic operator ensuring the product complies with the required regulations.

ASSMANN Electronic GmbH
 Auf dem Schüffel 3
 Lüdenscheid, Germany
<https://www.assmann.com>
info@assmann.com