

ASSMANN ELECTRONIC GmbH

ASSMANN SYSTEM GUARANTEE

DIGITUS® Copper Cabling System

Appendix B - Provisions for acceptance

Table of contents

1. Acceptance test of the installation link
2. Calibration of the measurement devices/adapters
3. Measurements / measured values
4. Acceptance test of classEA 6A (CAT 6A) – E (CAT 6) permanent links

1. Acceptance test of the installation link

The installation link must be subjected to acceptance testing on the basis of the test setup prescribed for the category or class to be tested. Observe the requirements of the standard chosen for the installation. Perform acceptance tests using ASSMANN-approved measurement devices only. Values obtained from measurements of the transmission path that do not match the prescribed test set-ups are invalid. Readings from measurement devices that do not appear in the approved equipment list are invalid.

2. Calibration of the measurement devices / adapters

Measurement devices must be calibrated by the manufacturer's test laboratory at regular intervals. The last calibration run should not be more than 15 months ago (prior to the date of the acceptance test). The measurement adapters must not exceed the permissible number of mating cycles (as specified by the manufacturer).

3. Measurement / measured values

Take the measured values by applying the settings prescribed in the appropriate standard.

The values obtained from the measurement of the transmission paths must be in accordance with the threshold values defined in the standard. If supported by the measurement device, store the measured data together with diagrams of the measured values. Report the measured data in electronic form. Mail the measured data in a file format (.flw or .sdf, depending on the equipment type) to systemwarranty@assmann.com or send them on a conventional data storage device (CD, DVD, USB stick) to ASSMANN.

4. Acceptance test for class EA (CAT 6A) – D (CAT 5e) permanent links

4.1 Measurement setup:

Messaufbau
Test Setup

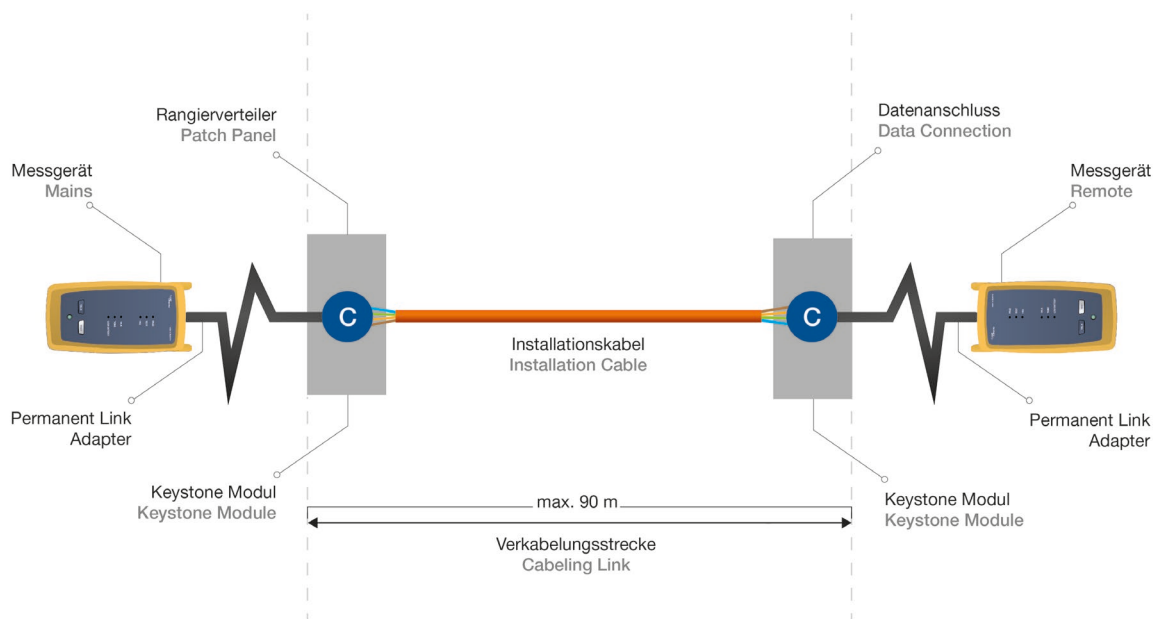

4.2 Acceptance test for class EA / CAT 6A permanent links

Applicable standards:

Class EA:

- EN 50173-1:2011
- ISO/IEC 11801:2002/A2:2010

CAT 6A:

- TIA/EIA 568 C.2-10

Approved measurement devices for acceptance testing of class Ea / CAT 6A:

Measurement device	Permanent link adapter	DIGITUS® test cable	File format
Fluke DTX 1800	RJ45 (DTX-PLA002)	-	*.flw
Fluke DSX 5000	PL RJ45 (DSX-PLA004S)	-	*.flw
Fluke DSX 8000	PL RJ45 (DSX-PLA804)	-	*.flw
Softing	WireXpert 4500 & 4500-Pro		*id
Softing	WireXpert 500_Cu; Plus		*id
IDEAL Lantek 6A/7G IDEAL Lantek III & IV	RJ45 (High Performance Category 6A)	DIGITUS® patch cable DK-1644-A-020	*.sdf

(Subject to technical modifications)

4.3 Acceptance test class E / CAT 6 permanent links

Applicable standards:

Class E:

- EN 50173-1:2011
- ISO/IEC 11801:2002/A2:2010

CAT 6:

- TIA/EIA 568 C. 2-10

Measurement device	Permanent link adapter	DIGITUS® test cable	File format
Fluke DTX 1800	RJ45 (DTX-PLA002)	-	*.flw
Fluke DSX 5000	PL RJ45 (DSX-PLA004S)	-	*.flw
Fluke DSX 8000	PL RJ45 (DSX-PLA804)	-	*.flw
Softing	WireXpert 4500 & 4500-Pro		*id
Softing	WireXpert 500_Cu; Plus		*id
IDEAL Lantek 6A/7G IDEAL Lantek III & IV	RJ45 (High Performance Category 6A)	DIGITUS® patch cable DK-1644-A-020	*.sdf